

ALUMINUM STANDS FOR HEAT PUMP UNIT

- 1- THIS EQUIPMENT UNIT STAND SYSTEM SHOWN ON THIS PRODUCT EVALUATION DOCUMENT (P.E.D) HAS BEEN VERIFIED FOR CODE COMPLIANCE IN ACCORDANCE WITH THE 2023 (8th EDITION) OF THE FLORIDA BUILDING CODE AND CHAPTER 20 OF THE SAME, FOR USE WITHIN THE HIGH VELOCITY HURRICANE ZONE (HVHZ) OR OUT OF IT. DESIGN PRESSURES CALCULATED FOR USE WITH THIS SYSTEM HAVE BEEN DETERMINED FOR A LATERAL LOAD OF 20LB/FT ON RAIL ANGLE ASSUMED FOR STAND STABILITY DESIGN, ALTHOUGH NO ATTACHMENT TO THE FLOOR SURFACE HAS BEEN CONSIDERED.
- 2- STANDS SHALL BE USED IN ENCLOSED INTERIOR SPACES ONLY, WHERE WIND LOADS WILL NOT BE IMPOSED ON THE AIR HANDLER UNIT. WIND LOADS HAVE NOT BEEN CONSIDERED IN DESIGN.
- 3- THE EXISTING HOST STRUCTURE MUST BE CAPABLE OF SUPPORTING THE LOADED SYSTEM AS VERIFIED BY BUILDING DEPARTMENT OR ARCHITECT / ENGINEER OF RECORD. NO WARRANTY, EITHER EXPRESSED OR IMPLIED, IS CONTAINED HEREIN.
- 4- STAND SHALL BE INSTALLED WITH MINIMUM AND MAXIMUM CLEAR HEIGHT AS INDICATED ON THIS P.E.D.
- 5- OPTIONAL VIBRATION ISOLATOR PADS MAY BE PROVIDED AT BOTTOM OF POST.
- 6- ELECTRICAL GROUND , WHEN REQUIRED , TO BE DESIGNED & INSTALLED BY OTHERS. ALL MECHANICAL SPECIFICATIONS (CLEAR SPACE, TONNAGE, ETC.) SHALL BE AS PER MANUFACTURER RECOMMENDATIONS AND ARE THE EXPRESS RESPONSIBILITY OF THE CONTRACTOR.
- 7- MAXIMUM DIMENSIONS AND WEIGHT OF AIR HANDLER UNIT SHALL CONFORM TO SPECIFICATIONS STATED HEREIN, SEE SHEET 3 FOR LIMITATIONS.
- 8- ALL SCREWS & BOLTS SHALL BE AS SPECIFIED ON THIS DRAWING, AND SHALL COMPLY WITH SECTION 2411.3.3.4 OF THE FLORIDA BUILDING CODE.
- 9- ALL ALUMINUM EXTRUSIONS SHALL BE OF REQ'D ALLOY & TEMPER AS PER BILL OF MATERIAL ON SHEET 2, UNLESS NOTED OTHERWISE. WELDING SHALL BE PERFORMED IN ACCORDANCE WITH AWS D 1.2 REQUIREMENTS, USING 5356 FILLER ALLOYS.
- 10- CONNECTION OF HEAT PUMP UNIT TO STAND (IF REQUIRED BY HEAT PUMP MANUFACTURER) IS NOT INCLUDED ON THIS P.E.D., BUT SHALL BE PERFORMED AS PER MANUFACTURER'S SPECS.
- 11- ALL ALUMINUM EXTRUSIONS IN CONTACT WITH DISSIMILAR MATERIALS SHALL COMPLY WITH SECTION III-6 OF THE 2020 ALUMINUM DESIGN MANUAL.
- 12- ENGINEER SEAL AFFIXED HERETO VALIDATE STRUCTURAL DESIGN AS SHOWN ONLY. USE OF THIS SPECIFICATION BY CONTRACTOR, et. al. INDEMNIFIES & SAVES HARMLESS THIS ENGINEER FOR ALL COST & DAMAGES INCLUDING LEGAL FEES & APPELLATE FEES RESULTING FROM MATERIAL FABRICATION, SYSTEM ERECTION, CONSTRUCTION PRACTICES BEYOND THAT WHICH IS CALLED FOR BY LOCAL, STATE, & FEDERAL CODES & FROM DEVIATIONS OF THIS PLAN. EXCEPT AS EXPRESSLY PROVIDED HEREIN, NO ADDITIONAL CERTIFICATIONS OR AFFIRMATIONS ARE INTENDED ON THIS DOCUMENT.
- 13- WATER-TIGHTNESS OF EXISTING HOST SUBSTRATE SHALL BE THE FULL RESPONSIBILITY OF THE INSTALLING CONTRACTOR. CONTRACTOR SHALL ENSURE THAT ANY REMOVED OR ALTERED WATERPROOFING MEMBRANE IS RESTORED AFTER FABRICATION AND INSTALLATION OF STRUCTURE PROPOSED HEREIN. THIS ENGINEER SHALL NOT BE RESPONSIBLE FOR ANY WATERPROOFING OR LEAKAGE ISSUES WHICH MAY OCCUR AS WATER-TIGHTNESS SHALL BE THE FULL RESPONSIBILITY OF THE INSTALLING CONTRACTOR.

- 14- (a) THIS P.E.D. (PRODUCT EVALUATION DOCUMENT) PREPARED BY THIS ENGINEER IS GENERIC AND DOES NOT PROVIDE INFORMATION FOR A SITE SPECIFIC PROJECT; i.e. WHERE THE SITE CONDITIONS DEVIATE FROM THE P.E.D.
 - (b) CONTRACTOR TO BE RESPONSIBLE FOR THE SELECTION, PURCHASE AND INSTALLATION INCLUDING LIFE SAFETY OF THIS PRODUCT, BASED ON THIS P.E.D., PROVIDED HE/SHE DOES NOT DEVIATE FROM THE CONDITIONS DETAILED ON THIS DOCUMENT. CONSTRUCTION SAFETY AT SITE IS THE CONTRACTOR'S RESPONSIBILITY.
 - (c) THIS P.E.D. WILL BE CONSIDERED INVALID IF ALTERED BY ANY MEANS.
 - (d) SITE SPECIFIC PROJECTS SHALL BE PREPARED BY A FLORIDA REGISTERED ENGINEER OR ARCHITECT WHICH WILL BECOME THE ENGINEER OF RECORD (E.O.R.) FOR THE PROJECT AND WHO WILL BE RESPONSIBLE FOR THE PROPER USE OF THE P.E.D.
 - (e) ORIGINAL P.E.D. SHALL BEAR THE DATE AND ORIGINAL SEAL AND SIGNATURE OF THE PROFESSIONAL ENGINEER OF RECORD THAT PREPARED IT.
- 15- THIS PRODUCT EVALUATION DOCUMENT (P.E.D) MUST BE SIGNED BY THIS ENGINEER WHEN USED FOR APPLYING FOR A BUILDING PERMIT.

THIS DRAWING SHALL ONLY BE USED TO OBTAIN PERMITS IN THE STATE OF FLORIDA

FLORIDA BUILDING CODE (High and Non High Velocity Hurricane Zone)

DRAWN BY: W.H
01/05/24

DATE

DRAWING No
23-247

ALUMINUM STANDS FOR HEAT PUMP UNIT.

F&L ALUMINUM PARTS, INC.
2087 N. POWERLINE RD. SUITE #1
POMPANO BEACH, FL. 33069

REV. No	DATE	REV. No	DATE	DESCRIPTION
1	01/05/24	3	-	① REDUCED
2	-	4	-	-

REV. No	DATE	REV. No	DATE	DESCRIPTION
1	01/05/24	3	-	① REDUCED
2	-	4	-	-

© 2024 TILTECO INC.

TILTECO INC.

TILIT TESTING & ENGINEERING COMPANY
6355 N.W. 30th St. Ste. 305 VEROBEACH, FLORIDA 33166
Phone : (305)971-1530 Fax : (305)971-1531
e-mail: tiliteco@aol.com

WALTER A. TILIT JR. P.E.
CA-0006719
FLORIDA Lic. # 44167

THIS ITEM HAS BEEN DIGITALLY SIGNED AND SEALED BY

PRINTED COPIES OF THIS DOCUMENT ARE NOT CONSIDERED SIGNED AND SEALED AND THE SIGNATURE MUST BE VERIFIED ON ANY ELECTRONIC COPIES.
WALTER A. TILIT JR., P.E.
FLORIDA Lic. # 44167

ATTENTION BUILDING OFFICIAL:
THIS DRAWING WILL EXPIRE 4 DAYS AFTER THE DATE IS WAS SIGNED BY THIS P.E

BILL OF MATERIALS:

COMPONENT No.	DESCRIPTION	DIMENSIONS	MATERIAL	MANUFACTURER	NOTES
①	RAIL ANGLE	2.00" X 2.00" X 0.125"THK.	6061-T6 ALLOY.	-	SUPPORT FOR HEAT PUMP UNIT
②	ALUMINUM POST TUBE	1.50" X 1.50" X 0.093THK.	6061-T6 ALLOY.	-	WITH OPTIONAL VIBRATOR ISOLATOR PADS AT BOTTOM.
③	BOTTOM RAIL ANGLE	1.50" X 1.50" X 0.063THK.	6063-T5 ALLOY.	-	USE BELOW ① AND PARALLEL TO ①
④	INNER MEMBER CROSS BAR	0.75" X 0.75" X 0.063THK.	6061-T6 ALLOY.	-	ADJUSTABLE CROSS BAR PERPENDICULAR TO ①, W/⑥ CONNECTION
⑤	OUTER MEMBER CROSS BAR	1.00" X 1.00" X 0.063"THK.	6061-T6 ALLOY.	-	ADJUSTABLE CROSS BAR PERPENDICULAR TO ①, W/⑥ CONNECTION
⑥	CROSS BAR BOLT & NUT	1/4"Ø-20 X 1 1/2"MIN.	ASTM A-307 OF 304 S.S	-	USE AT SPLICE BETWEEN ④ & ⑤

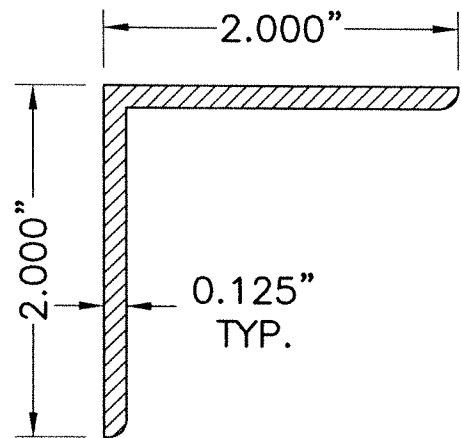

① RAIL ANGLE

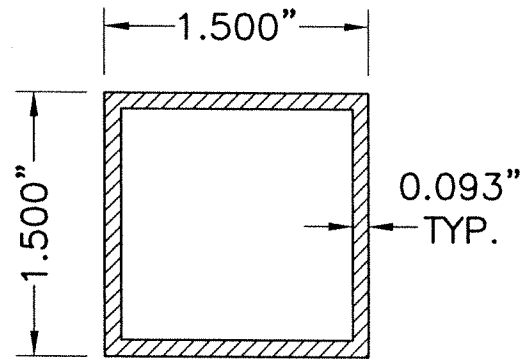

② ALUMINUM POST TUBE

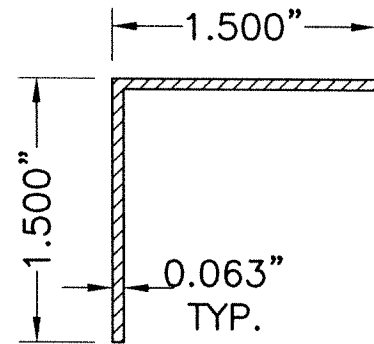

③ BOTTOM RAIL ANGLE

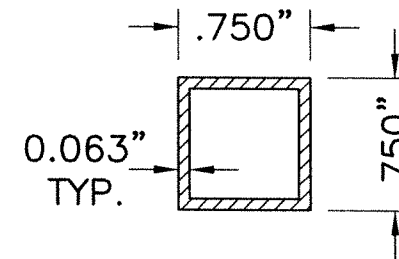

④ INNER MEMBER CROSS BAR

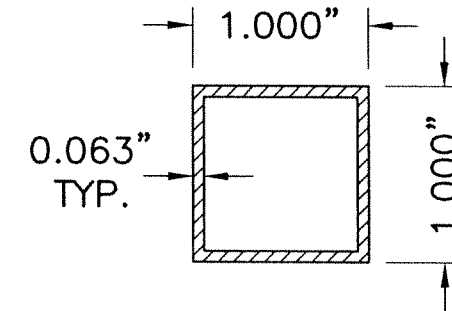

⑤ OUTER MEMBER CROSS BAR

COMPONENTS

SCALE: N.T.S

FLORIDA BUILDING CODE (High and Non High Velocity Hurricane Zone)

ALUMINUM STANDS FOR HEAT PUMP UNIT.

F&L ALUMINUM PARTS, INC.
 2087 N. POWERLINE RD. SUITE #1
 POMPANO BEACH, FL. 33069

© 2024 TILTECO INC.

TILTECO INC.
 TILLIT TESTING & ENGINEERING COMPANY
 6355 N.W. 15th St., 305 VIRGINIA GARDENS, FL 33166
 Phone: (305)971-1530 Fax: (305)971-1531
 e-mail: tilteco@ttil.com
 CA-0006719
 WALTER A. TILLIT JR., P.E.
 FLORIDA Lic. # 44167

THIS ITEM HAS BEEN DIGITALLY SIGNED AND SEALED BY

PRINTED COPIES OF THIS DOCUMENT ARE NOT CONSIDERED SIGNED AND SEALED AND THE SIGNATURE MUST BE VERIFIED ON ANY ELECTRONIC COPIES.

WALTER A. TILLIT JR., P.E.
FLORIDA Lic. # 44167

ATTENTION BUILDING OFFICIAL:
THIS DRAWING WILL EXPIRE 4 DAYS AFTER THE DATE IS WAS SIGNED BY THIS P.E

DRAWN BY: W.H
01/05/24

DATE

23-247
DRAWING No

SHEET 2 OF 3

REV. No.	DATE	DESCRIPTION
1	01/05/24	①, ⑤ REDUCED
2	-	-
3	-	-
4	-	-

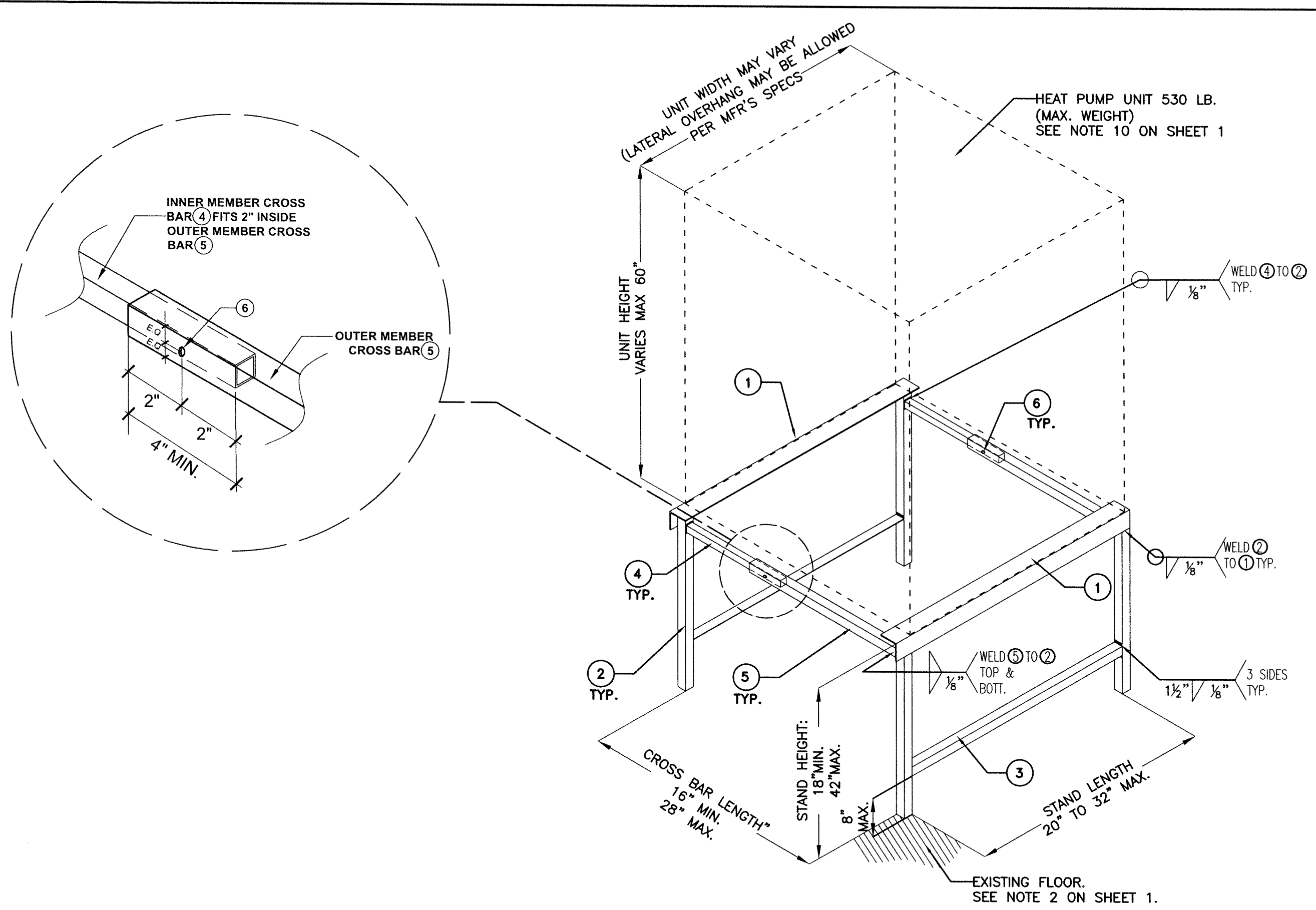

STAND ASSEMBLY
SCALE: N.T.S

FLORIDA BUILDING CODE (High and Non High Velocity Hurricane Zone)

ALUMINUM STANDS FOR HEAT PUMP UNIT.

F&L ALUMINUM PARTS, INC.
2087 N. POWERLINE RD. SUITE #1
POMPANO BEACH, FL. 33069

REV.	DATE	DESCRIPTION
1	01/05/24	ISSUED
2		REDUCED
3		
4		

© 2024 TILTECO INC.
TILTECO INC.
TILLIT TESTING & ENGINEERING COMPANY
6365 N.W. 13th St. Ste. 305, VIRGINIA GARDENS, FL 33166
Phone: (305) 971-1530 Fax: (305) 971-1531
e-mail: tilteco@aol.com
CA-0006719
WALTER A. TILLIT JR., P.E.
FLORIDA Lic. # 44167

DRAWN BY: W.H.
DATE: 01/05/24
DRAWING No: **23-247**
SHEET **3** OF 3

THIS ITEM HAS BEEN DIGITALLY SIGNED AND SEALED BY

PRINTED COPIES OF THIS DOCUMENT ARE NOT CONSIDERED SIGNED AND SEALED AND THE SIGNATURE MUST BE VERIFIED ON ANY ELECTRONIC COPIES.
WALTER A. TILLIT JR., P.E.
FLORIDA Lic. # 44167

ATTENTION BUILDING OFFICIAL:
THIS DRAWING WILL EXPIRE 4 DAYS AFTER THE DATE IS WAS SIGNED BY THIS P.E